

Trigger Measuring Device

E-DT-172 USER MANUAL

ZhongYuan JingMi CO.,LTD

Preface

Firstly, thank you for purchasing our trigger measuring device product. From now on, you can use advanced tools to solve production problems. At the same time, as this product can fully utilize the potential functions of the machine tool, you do not need to purchase other specialized equipment with similar functions but high prices, thus saving you valuable funds. In addition to being pleased, please read this product manual carefully before starting to use the purchased product, deeply understand and flexibly use this device, which will bring you unexpected gains.

In addition, if you encounter any difficulties, have any opinions or suggestions during the use of our company's products, please feel free to contact us through our after-sales hotline at any time. You can also log in to our company's website to learn about product information or contact us via email.

Telephone number: 0086398-2751816 , 2751818

<http://www.zyjm.com>

E-mail address: zyjm@zyjm.com

Precautions :

- 1) Before starting to use the probe, please read this manual carefully.
- 2) Before installing the device, the working logic of the output signal should be correctly selected, and then a multimeter should be used to check whether the output status of the measuring head signal is normal. Finally, manually check whether the CNC system of the machine tool has correctly received and processed the output signal of the measuring head, as detailed in the subsequent instructions.
- 3) When the user directly installs and uses the probe without following the above process for detection, if the output signal of the probe does not match the signal required by the CNC system of the machine tool, it may cause the machine tool to produce incorrect actions, resulting in damage to the probe or machine tool.
- 4) If users do not receive technical guidance from our company or do not have specialized tools, do not directly disassemble the measuring needle and the main body of the measuring head, otherwise it will damage the internal mechanism and circuit connections of the measuring head.
- 5) Liability exemption: Before using this device, users should sequentially check the signal and communication status of the measuring head according to the instructions in this manual. Only after the signal of the measuring head can be correctly received by the machine's system can the measuring head be used. Therefore, when the user starts using the

probe, our company will no longer bear the obligation of free maintenance for mechanical damage to the probe, nor will we assume any responsibility for machine tool, workpiece or fixture damage that occurs when the user uses the probe, regardless of whether the user infers that the damage to the probe and machine tool is caused by a malfunction of the probe.

6) Warranty commitment: Regardless of any damage to the measuring head during the use of this device, our company will bear the lifelong maintenance of the product.

1. Summary

The main body of this device has a special triggering mechanism inside. When the measuring needle comes into contact with other objects, once there is a slight change in the position of the measuring needle, the triggering mechanism will immediately trigger the measuring head circuit and output a switch signal. This triggering signal will continue until the measuring needle fully returns to its original position before it can end. So it is mostly used for positioning the end face of the measured workpiece.

2. Characteristic

(1)The nominal size of the measuring head

The volume of this device is very small, making it easy to install, adjust, and combine with other devices. Its main nominal dimensions are shown in the following figure.

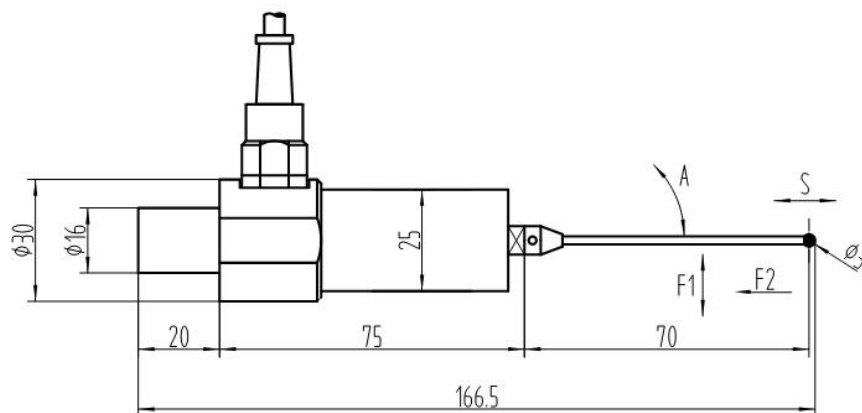

(2) Transmission and indication of measurement signals

When the probe is triggered, the trigger signal of the probe is output to the CNC system of the machine tool through a cable; At the same time, as an indicator signal, the light-emitting diode on the main body of the measuring head lights up.

(3) The protection stroke and reset accuracy of the measuring needle

The measuring needle of the device has a protection function of downward floating and arbitrary radial swing, where the distance of downward floating of the measuring needle is 5 millimeters, and the angle of arbitrary radial swing of the measuring needle is 12 degrees. In order to ensure the accuracy of continuous measurement by the measuring head, the measuring needle can automatically restore its initial position after a position change, and has a reset accuracy of no more than 1 micrometer.

(4) Replacement of measuring needles

The connection structure between the measuring needle of the device and the main body of the measuring head adopts standard M4 threads, so the measuring head can be connected to various types of measuring needles to meet different measurement requirements. Due to the structural size limitation of the device, the reset elasticity of the measuring needle is relatively small, so usually this type of device can only connect measuring needles with relatively small size specifications.

5. Protection of the device

This device adopts comprehensive measures in terms of protection, so that the protection level of the probe itself, cables, and cable joints reaches IP67 (anti immersion) level.

3. Technical parameters of the device

External length: 166.5 (mm) Weight: 470 (g)

Standard measuring needle length: 70 (mm)

Measuring ball diameter: 3.0 ± 0.00025 (mm)

The reset accuracy of the measuring needle is less than ± 0.002 (mm).

The downward floating stroke of the measuring needle is 5.0 (mm).

The swinging angle of the measuring needle in any direction is 12°

Radial reset elasticity of measuring needle: 100-160 (g)

Measuring needle axial reset elasticity: 900-1000 (g)

Installation handle form: radial outlet.

Installation handle diameter: 16 (mm)

Protection level: IP67 (anti soaking)

Red indicator light (LED): 1 piece

Input power voltage: $24 \pm 10\%$ (V DC)

maximum input current: 30mA

Cable: Oil proof cable, length 6 meters

SSR signal output: load current max50mA, load voltage max40V

4. Installation of the device

(1) Connection between measuring head and measuring needle

When installing the measuring needle, be sure to use the measuring needle wrench provided with the product. When operating, it is important to first use an open-ended wrench to fix the measuring needle holder with a threaded hole at the front end of the measuring head, and then screw in the measuring needle. When all the threads of the measuring needle are screwed in, use a cylindrical wrench to tighten the measuring needle appropriately.

(2) Signal connection method

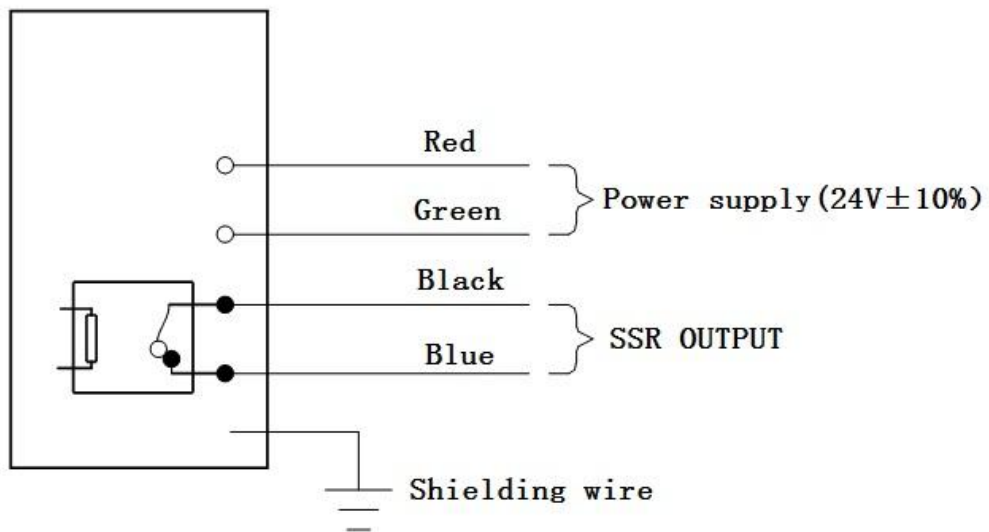

Power supply connection method		Signal output logic
Red	+24V	Normally open output
Green	0V	
Red	0V	Normally closed output
Green	+24V	

5. Warranty Description

- 1 This product warranty service is only valid for normal use:
- 2 Non product quality issues and malfunctions caused by abnormal use are not covered by warranty. For example: including However, malfunctions caused by the following circumstances are not covered by warranty:
 - (1) The device is unable to measure deformation, bending, etc. due to external impact;
 - (2) Unauthorized disassembly of the device by the user may result in loose components, oil leakage, or liquid ingress;
 - (3) Malfunctions caused by failure to use as required and the device operating beyond its normal range of application.

V1.2 202408

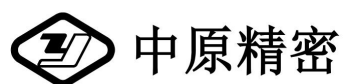

Sanmenxia ZhongyuanJingmi Co.,Ltd

Address: east ection of weiliu road, sanmenxia industrial park,

henan, China

Tel: 0398-2751818 Fax: 0398-2751819

Postcode: 472000

<http://www.zyjm.com>



Scan QR code→Support Service
→Download Center→ Manual