

MEASURING Device

QZ-LN3 USER MANUAL

ZhongYuan JingMi CO.,LTD

DANGER

Hazardous voltage can cause injury or death.

- Do not take out covers except when servicing or checking is required.
- Turn off the power switch of this system and disconnect the power supply cable before taking out covers. (For products having the relay contact output circuits, disconnect the input/output signal connectors, too.)

WARNINGS

Hydraulic cylinder, when used, driving gage head forward (downward) or backward (upward) can cause injury.

- Make sure the machine using this system is not operating before touching the hydraulic cylinder.

Driven contacts of gage head can cause injury.

- Make sure the machine using this system is not operating before touching the gage head contacts.

CAUTIONS

Be sure NOT to operate this system when the gaging unit and/or control unit are in failure (such as when the READY signal has gone off).

Heavy load or strong force can deform the covers of control unit.

- Do not stand or step on the cover of control unit.

Operation without connecting grounding wires can cause malfunction of the system or electrical shock.

- Make sure to connect every grounding wire of the power supply unit and the other units to ground.

Preface

This instrument has developed by our experienced engineers with their every possible effort and technical cream in ceaseless pursuit of accuracy, and carefully manufactured by our skilled technicians with the most recent production equipment. It has passed very strict tests and verified excellent performance, ensuring its reliable operation at your site,

However, this kind of instrument of high accuracy demands correct handling and maintenance for continuing utilization of its entire functions under the best condition.

This document describes the points on correct and safety handling that the persons daily using this instrument must well know. We hope that this document can help you for the good use of this instrument.

Precautions

- 1) The gaging units under this Guide can form various gaging systems with our control units depending on applications.
For detail of a specific system configuration, see the separate Operation Manual of the system. (For a rather simple system configuration, its system Operation Manual may not be provided.)
- 2) Greatest care must be taken that an excessive shock or falling-down by mistake may result in malfunction of gage heads.
- 3) Gage head cables must be run without any possibility of compression or damage due to metal chips or moving items.
Fix the cable end of gage head side to protect it from friction and extension by the gage head movement.
- 4) Run each gage head cable apart from power cables of the other equipment more than 200mm, and use a separate duct.
- 5) Do not open covers of gage heads.
Do not turn or loosen clamp screws, adjusting screws or other screws without purposes.

CONTENTS

| | |
|---|---|
| DANGER..... | 1 |
| WARNINGS..... | 1 |
| CAUTIONS..... | 1 |
| Preface..... | 2 |
| Precautions..... | 2 |
| Contents..... | 3 |
| 1. General..... | 4 |
| 2. Features..... | 4 |
| 2.1 High precision..... | 4 |
| 2.2 Long lifespan and high reliability..... | 4 |
| 2.3 Easy maintenance..... | 4 |
| 2.4 Easy installation..... | 5 |
| 3. Types and specifications..... | 5 |
| 4. Installation and commissioning of measuring devices..... | 5 |
| 4.1 Confirm that the probe does not collide with the workpiece..... | 6 |
| 5. Zero position setting..... | 7 |
| 5.1 Installing standard parts onto the machine tool..... | 7 |
| 5.2 Turn on the controller to display the original data status..... | 7 |
| 5.3 Move the measuring device forward and enter the measurement position..... | 7 |
| 5.4 Adjusting the measuring rod on the measuring device..... | 7 |
| 6. Precautions..... | 9 |
| 7. Warranty Description..... | 9 |

1 .General

The QZ-LN3 measuring device is an ideal device for active measurement in crankshaft grinding. Due to its excellent design and ultra-thin (thickness 9mm) structure, it can be used for measuring various specifications of crankshaft parts, greatly improving product quality and production efficiency.

2 . Features

2.1 High precision

The QZ-LN3 measuring device has a high measurement accuracy due to the absence of sliding and friction mechanisms in its internal structure.

2.2 Long lifespan and high reliability

The QZ-LN3 measuring device uses a unique elastic structure internally, which meets the high lifespan and reliability of online measuring instruments.

2.3 Easy maintenance

The key components inside the QZ-LN3 series measuring device are all module combinations, making service and maintenance very simple.

2.4 Easy installation

By adjusting the measuring device's fine tuning mechanism or replacing the upper and lower measuring rods (or gauges), different diameter ranges of crankshaft parts can be measured, and different installation positions can be adopted according to the special needs of the machine tool.

3 Types and specifications

The outline diagram of QZ-LN3 is shown in the figure

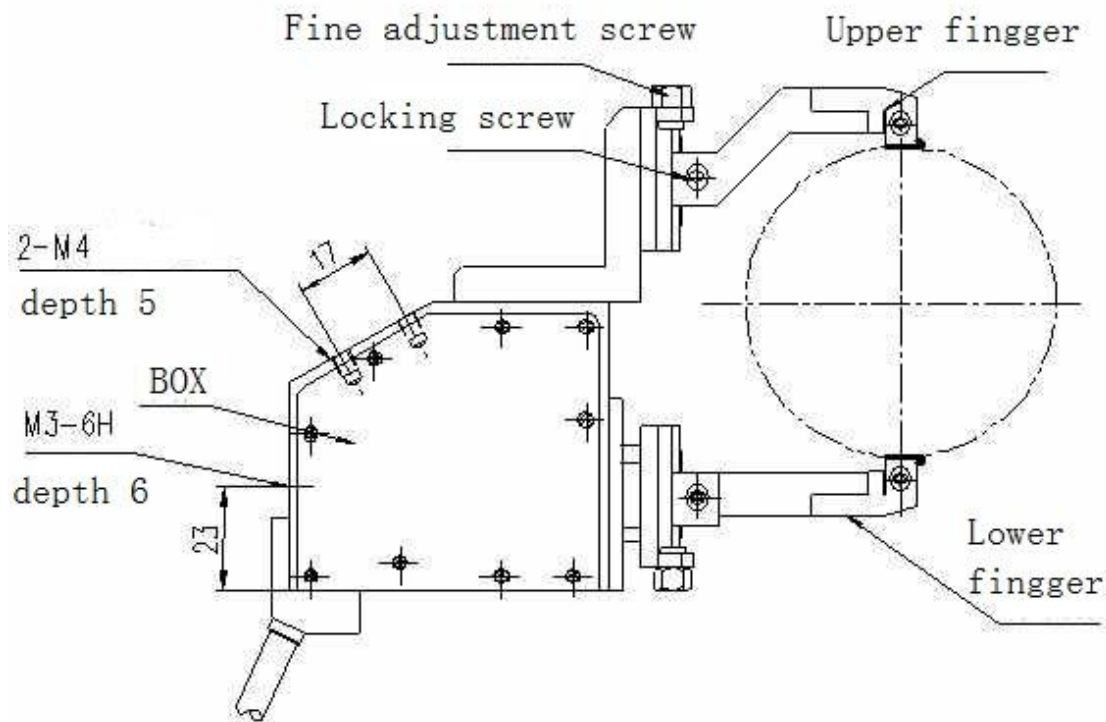

4. Installation and commissioning of measuring devices

The following items must be carried out when using the measuring device for the first time or after replacing the measuring rod or probe, otherwise it may cause damage to the measuring device or prevent correct measurement.

4.1 Confirm that the probe does not collide with the workpiece

As shown in Figure 1, it is a schematic diagram of QZ-LN3. Firstly, loosen the locking screws of the upper and lower measuring rods. According to the size of the standard part, rotate the upper and lower fine adjustment screws respectively to ensure that there is a 1-2mm gap between the measuring device and the standard part when entering the measuring position, so that there will be no serious collision between the measuring device and the standard part when entering the measuring position during zero position adjustment. At this time, be careful not to lock the locking screws temporarily, and zero position adjustment will also be carried out in the future.

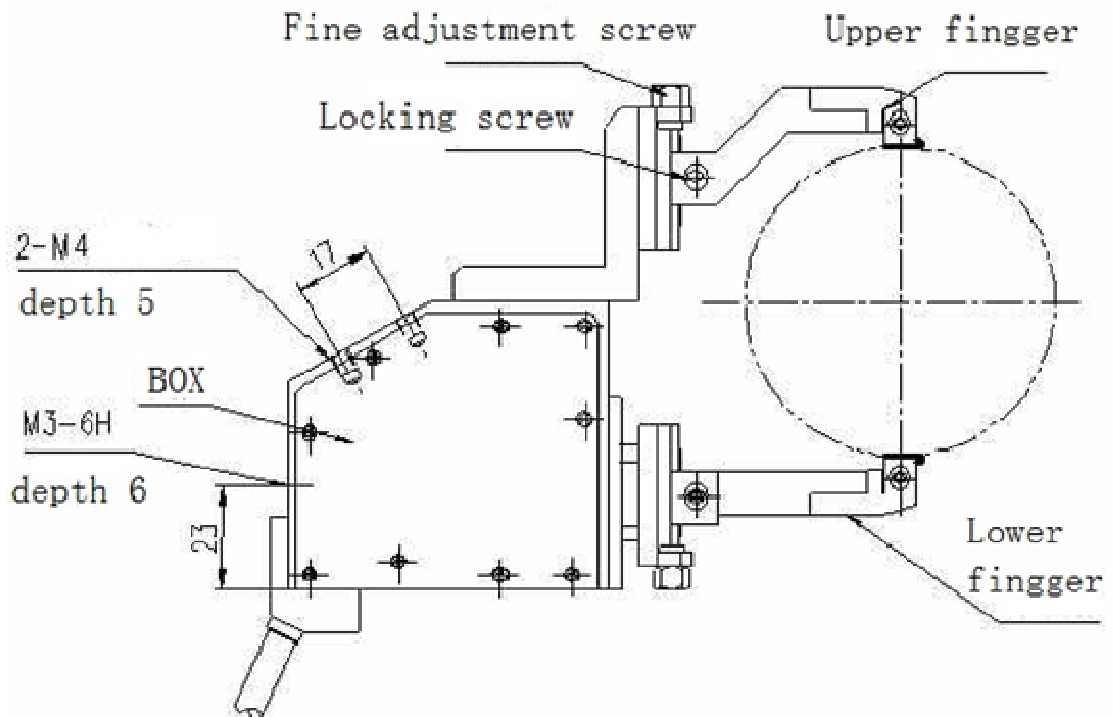



Figure 1

5. Zero position setting

When using it for the first time, stopping it for a long time, or changing the measurement specifications, it is necessary to reset the zero position. When setting the zero position, be sure to wipe the surface of the standard parts and measuring instruments clean.

5.1 Install standard parts onto the machine tool

5.2 Enter the startup interface and press the  or  key at the bottom of the interface to set the displayed value after compensation to 0.



5.3 Move the measuring device forward and enter the measurement position.

5.4 Adjusting the measuring rod on the measuring device (fixed side of the measuring rod)

5.4.1 As shown in Figure 2, adjust the fine adjustment screw of the upper measuring rod to make contact between the measuring rod and the standard part. Pay attention that the contact point between

the measuring rod and the standard part should be at a height of about 1-2mm from the highest point chord, and tighten the locking screw of the upper measuring rod.







图 2

5.5 Adjusting the measuring rod

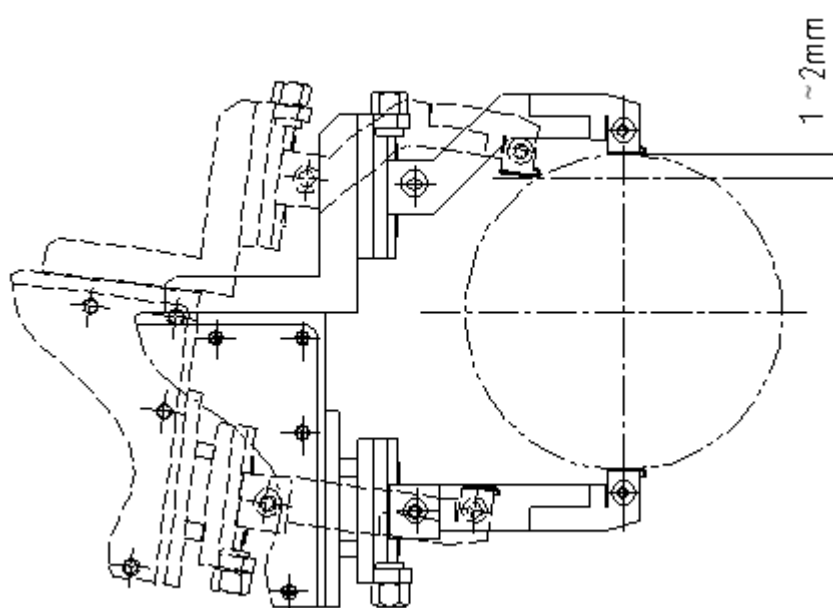
As shown in Figure 2, click the  button and the system will enter the adjustment window. The interface will display G1. Adjust the fine adjustment screw of the lower measuring rod, slightly lock the measuring rod (be careful not to apply too much force, as adjustments need to be made below), continue adjusting the fine adjustment screw, observe the display value of the control instrument to display "0" (or within $\pm 30 \mu$), and then lock the lower measuring rod. After locking, the display value of the control instrument may

change slightly. If there is a change, repeat this process to display the value after locking the dovetail or within $\pm 30 \mu$. At this point, press the  button to display The value becomes 0, the probe compensation value enters the zero value, and the adjustment is complete. Press the  button to enter the measurement interface. Move the measuring device back and forth a few times to confirm whether the zero position has been adjusted properly.

Zero position adjustment completed.

6. Precautions

6.1 The force measurement and front stroke of the measuring device have been adjusted according to the different user requirements before the product leaves the factory. Please do not adjust them randomly during use. If it is necessary to readjust, it must be done under the guidance of professional personnel.

6.2 When installing the measuring device onto the machine tool, please be careful not to damage the cable of the device. Additionally, during the movement of the measuring device, please fix the cable to avoid stretching or friction.

6.3 Except for professionals, please do not open the measuring device. Do not loosen the fastening screws and other fasteners on the measuring device at will.

The cable of the measuring device should be kept at least 200mm

away from other power lines.

7. Warranty Description

7.1. This product warranty service is only valid for normal use:

7.2. Non product quality issues and malfunctions caused by abnormal use are not covered by warranty. For example: including

However, malfunctions caused by the following circumstances are not covered by warranty:

(1) The device is unable to measure deformation, bending, etc. due to external impact;

(2) Unauthorized disassembly of the device by the user may result in loose components, oil leakage, or liquid ingress;

(3) Malfunctions caused by failure to use as required and the device operating beyond its normal range of application.

V1.3 202407

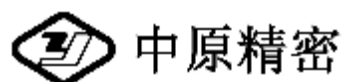

Sanmenxia ZhongyuanJingmi Co.,Ltd

Address: east ection of weiliu road, sanmenxia industrial park,

henan, China

Tel: 0398-2751818 Fax: 0398-2751819

Postcode: 472000

<http://www.zyjm.com>



Scan QR code →Support Service
→Download Center→ Manual